



Engineering Flow Solutions

**HMS Ciris**

**BOREHOLE SUBMERSIBLE PUMPS**



# Borehole Submersible Pumps

## HMS Ciris



The HMS CIRIS pumps have been engineered in accordance with the modern requirements to energy efficiency and reliability taking into account the heavy duty operation with unstable power supply quality.

The pumps are distinguished by reinforced design of the casing parts that significantly reduces the risk of mechanical damage during transportation, installation, operation and maintenance of the pumps.

The pumps are equally applicable in vertical position (boreholes, water wells, ground water lowering pits) or horizontal position (water reservoirs, fountains, pressure booster modules, and other systems).

The HMS Ciris pumps are manufactured at the largest in Russia borehole submersible pump manufacturing facilities of Livnynasos (HMS Group).

### Application

- Drinking and service water supply in industrial, municipal and rural areas
- Irrigation and spray irrigation in agriculture
- Mining industry dewatering and water supply systems
- Pressure boosting applications
- Groundwater lowering and level maintaining
- Firefighting and sprinkler systems

### Technical Data

Capacity range	4 – 290 m <sup>3</sup> /h
Head range	up to 550 m
Electric motor power	up to 130 kW
Rotation speed	3000 rpm
Motor protection	IPx68
Motor starts per hour	≤ 20
Starting method	Direct-Online
Rated voltage	50 Hz, 3x400 V
Voltage deviation	-15...+10%
Minimal cooling flow rate:	0.2 m/sec

### Operating Conditions

Pumped liquid.....	water
Liquid temperature.....	up to 30 °C
Total dissolved solids.....	up to 1500 mg/l
pH indicator .....	6.5 – 9.5
Sulphates.....	up to 500 mg/l
Chlorides .....	up to 350 mg/l
Hydrogen sulfide .....	up to 1.5 mg/l
Sand .....	up to 100 mg/l

## Design Features & Advantages

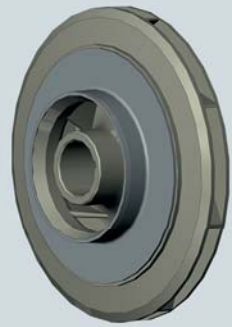

Fig. 1. Plastic impellers reinforced with stainless steel

### Pump

1. Built-in non-return valve prevents water hammer and reverse rotation
2. Stainless steel thick-tube stages casings provide high structural rigidity and damage prevention during installation and better corrosion protection of the pump stages
3. Stainless steel corrosion-resistant straps
4. Patented design of the plastic impellers reinforced with stainless steel notably increases their service life (Fig. 1)

The 8" diameter pumps are optionally equipped with high-strength plastic impellers or complete stainless steel impellers (option)

The pumps with capacity over 100 m<sup>3</sup>/h are completely made of stainless steel including impellers, diffusers, and stages casings

5. The shaft is made of stainless steel for high resistance to corrosion
6. Octagonal bearings provides better sand removal
7. The expeller vanes ensure hydraulic unloading of impellers from axial force and dramatically increase the operation lifetime of a thrust bearing in the electric motor (Fig. 2)
8. Built-in strainer in the suction inlet prevents ingress of the coarse particles into the pump

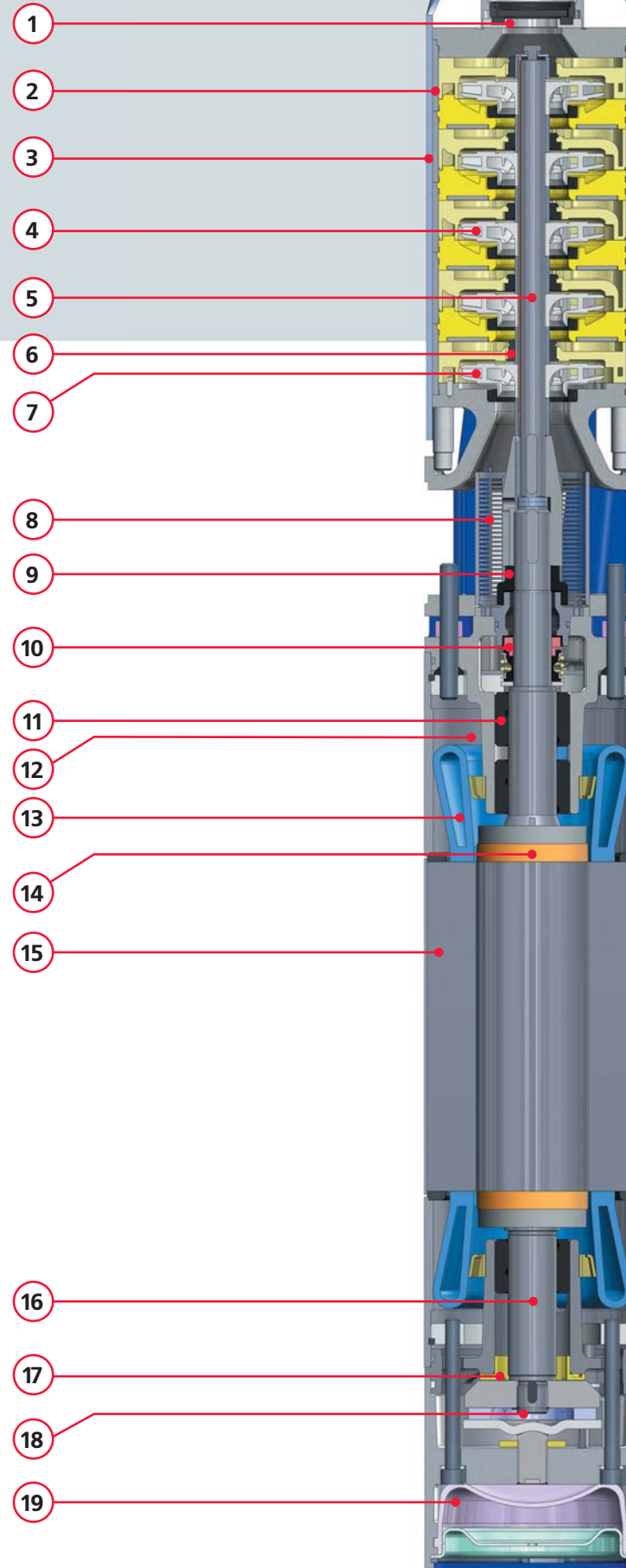

## Borehole Submersible Pumps HMS Ciris

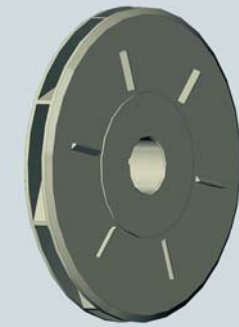
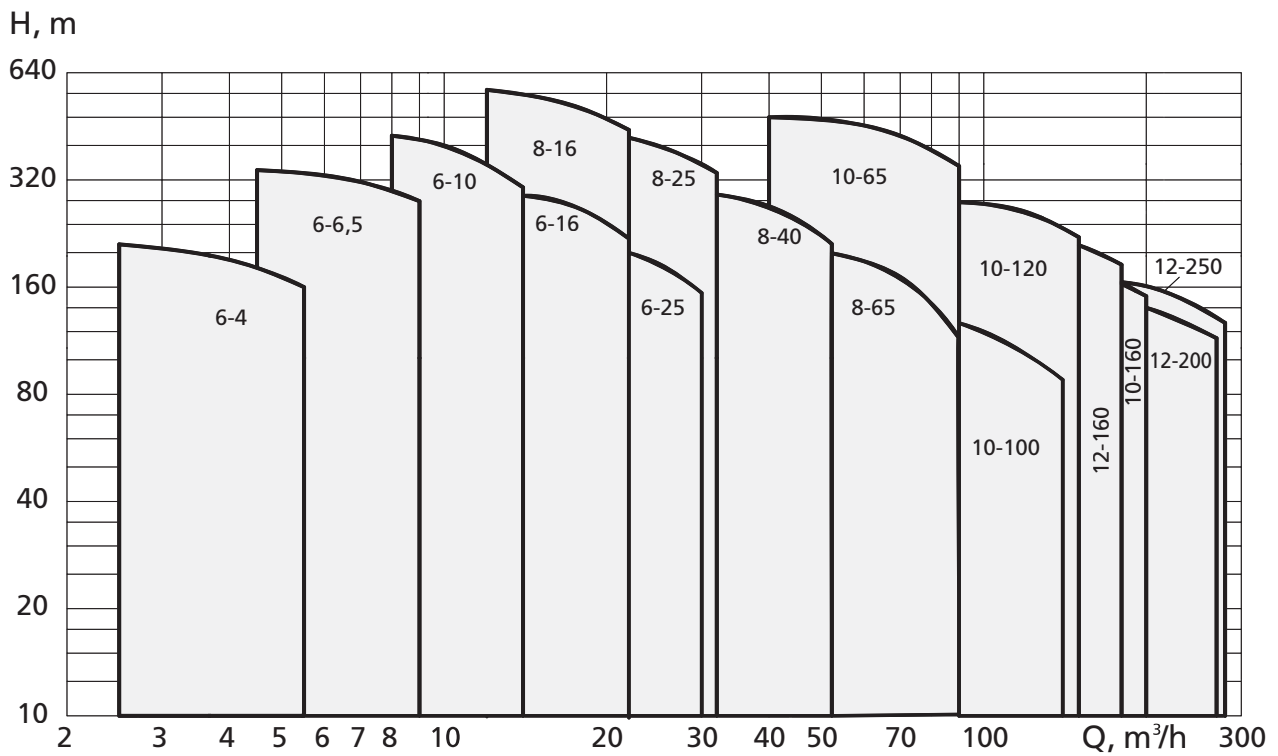

Fig. 2. Expeller vanes for hydraulic unloading from axial force

### Electric Motor

9. Sand guard protects the motor from ingress of the sand particles
10. Mechanical seal isolates the internal cavity of the motor from the pumped media
11. Radial bearings of advanced composite (graphite-based) material with helical grooves providing better lubrication
12. Motors are filled with a liquid allowing contact with potable water and may be stored at low temperatures down to -30 °C. Motors can be refilled with clean fresh water
13. High-temperature insulated (PE2/PA) winding wire (up to 100 °C)
14. Squirrel cage type rotor made of copper ensures increased reliability and efficiency in comparison with aluminum rotor
15. Increased length of stator and rotor enhances reliability and improves cooling conditions to withstand bad voltage quality
16. Stainless steel corrosion-resistant shaft
17. Reverse thrust bearing prevents rotor's vertical displacement
18. Self-aligning water lubricated thrust bearing ensures reliable and trouble-free operation
19. Rubber membrane compensate the liquid thermal expansion inside the motor

# Performance Range



## Pump Series Designation

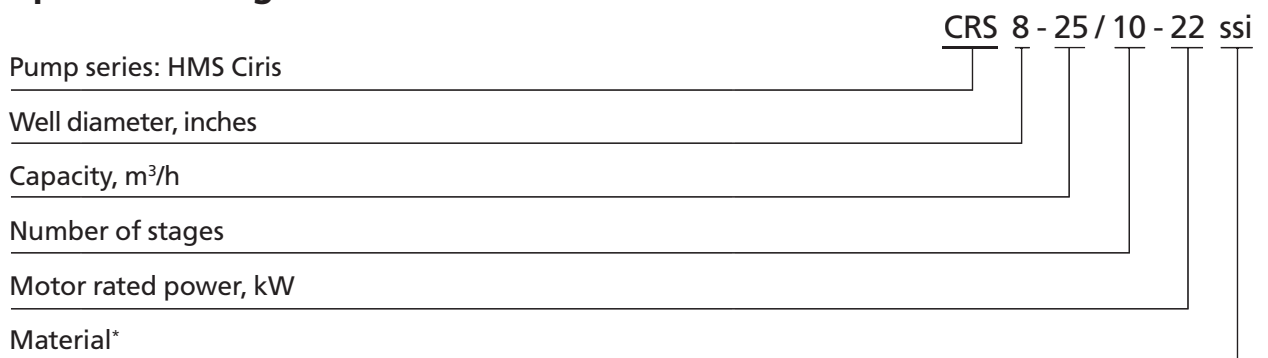

\* Options (if applicable): ssi - stainless steel impeller, ssp - stainless steel pump

**HMS Group Moscow  
International Sales Department**

Phone: + 7 (495) 730 6601 (ext. 2112)  
Fax: + 7 (495) 730 6602  
E-mail: [export@hms.ru](mailto:export@hms.ru)  
[www.grouphms.com](http://www.grouphms.com) [www.hms.biz](http://www.hms.biz)

**Sales Office in Dubai**

Phone: + 971 (552) 152-725  
E-mail: [rajrazdan@hms.ru](mailto:rajrazdan@hms.ru)

Information contained in this brochure is for reference purposes and to select products developed and manufactured by HMS Group. You can find full technical information on all our products in the relevant technical manuals.

HMS Group reserves the right to alter their products without notice and is not responsible for possible errors in catalogs, brochures and other printed materials.